



## 6-18 GHz Circulator

### Description

A circulator is a 3 port non-reciprocal passive RF device that allows unidirectional signal transmission while preventing signal flow in the reverse direction. A single junction circulator packaged in a ruggedized Kovar package. Three female SMA connector allow for easy hook up. 10-watt (CW) power handling capability.

### Features

- Hermetic Package
- SMA Connector (18 GHz)
- Flat Performance
- Low loss
- Ruggedized design.
- Frequency Stable over temperature
- 10 Watt (CW) power handling
- 10 dB Minimum Isolation



### Applications

- Measurement
- Radar
- Antenna arrays



**Electrical Specifications ( $T_{op} 23 \pm 3^{\circ}C$ , unless otherwise specified)**

Parameter	Min.	Typ.	Max.	Unit	Test Conditions
Return Loss	13	15		dB	6-18 GHz
Insertion Loss		1		dB	6-18 GHz
Isolation	10	15		dB	6-18 GHz

Typical Electrical Specifications. Insertion loss may vary up to +/- 0.5 dB

**Typical Measured Performance** - Performance may vary device to device

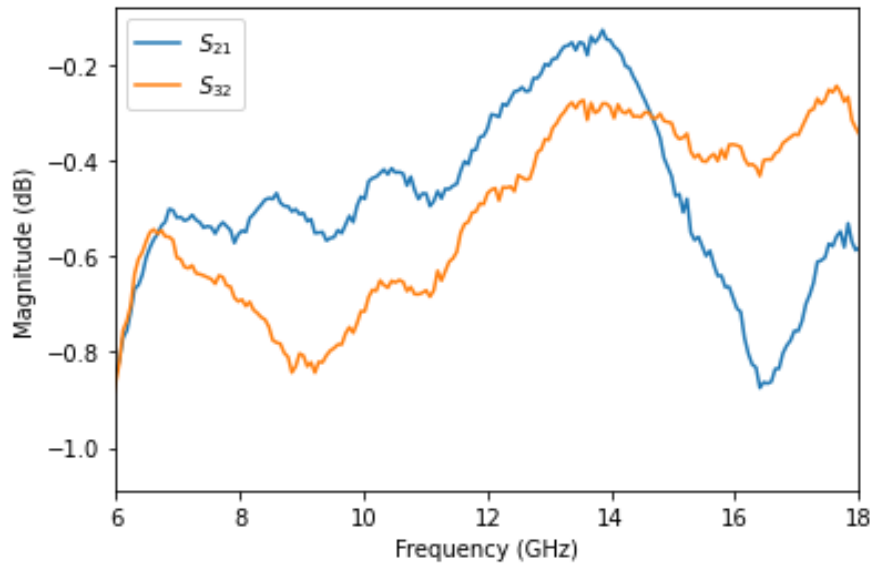
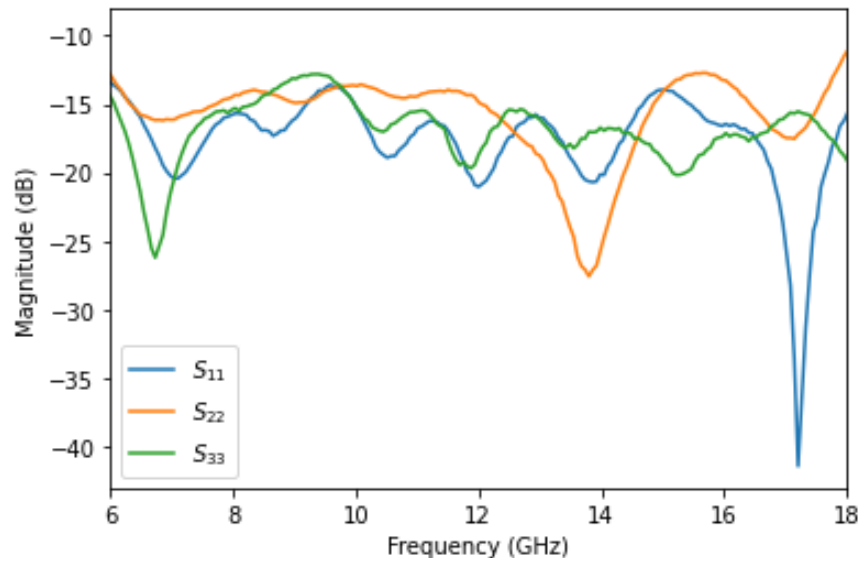

**Isolation Performance:**

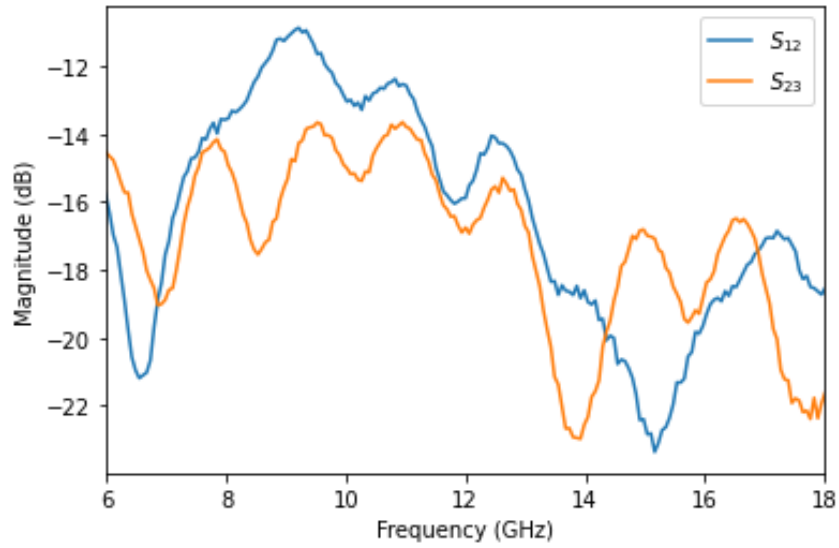

**Current Direction**

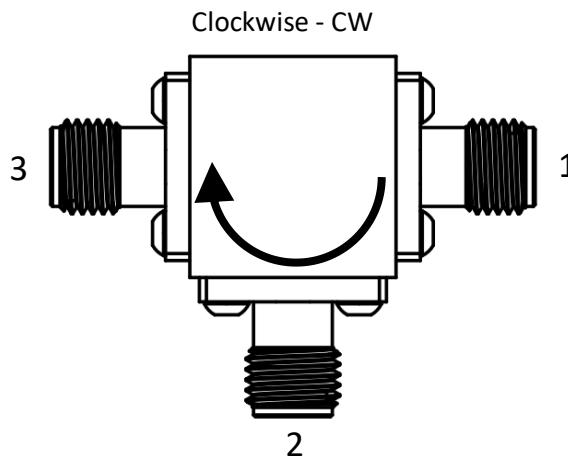

**Device Dimensions**

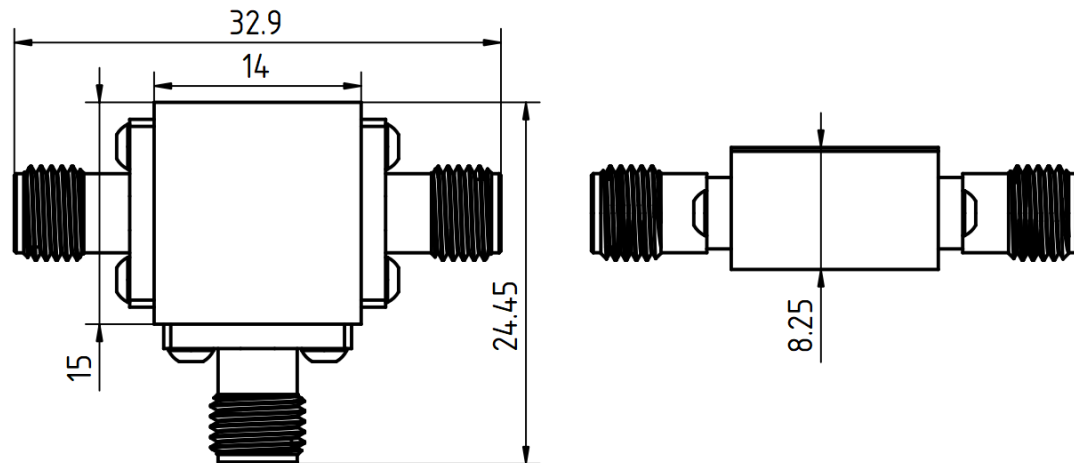
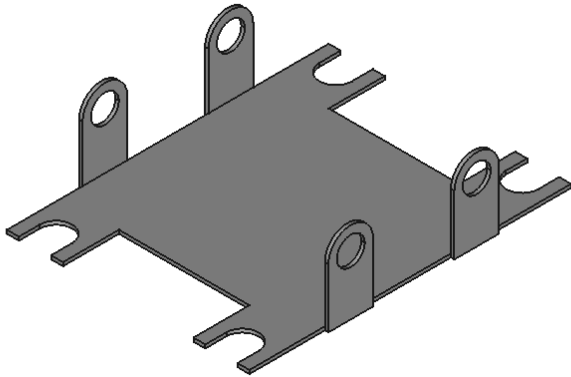
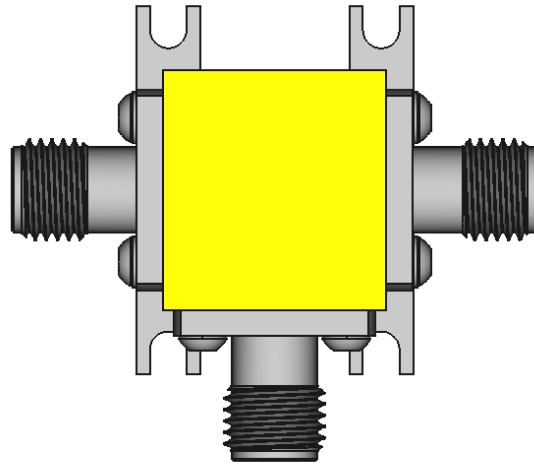

Figure 1. All units in mm. Manufactured device sizes may differ.

**Optional Mount:** If is desirable to mechanically fix the device in place. An optional Mount can be added to the device.



(a) Mount



(b) Mount on the device

#### Inquiry Information

**Sales:** All inquiries regarding sales please contact [Sales@NuPhotonics.com](mailto:Sales@NuPhotonics.com)

**General:** If you are interested in a custom solution, general information, or engineering related information please contact [Inquiry@NuPhotonics.com](mailto:Inquiry@NuPhotonics.com)



# IMPORTANT NOTICES AND DISCLAIMERS

Warranty: NUPHOTONICS PROVIDES ALL OF THE INFORMATION ON TECHNICAL AND RELIABILITY DATA. THIS INCLUDES INFORMATION PRESENTED IN DATA SHEETS, DESIGN FILES, APPLICATIONS, AND OTHER RESOURCES "AS IS" AND WITH ALL FAULTS, AND DISCLAIMS ALL WARRANTIES, EXPRESS AND IMPLIED, INCLUDING WITHOUT LIMITATION ANY IMPLIED WARRANTIES OF MERCHANTABILITY, FITNESS FOR A PARTICULAR PURPOSE OR NON-INFRINGEMENT OF THIRD-PARTY INTELLECTUAL PROPERTY RIGHTS.

The information and resources are presented and intended for developers that are skilled and adequately qualified to work with this technology. You, the customer, are solely responsible for and accept full responsibility for selecting the appropriate NuPhotonics devices for your application. You accept the sole responsibility of designing, validating, and testing your application. You bear all responsibility for your application meeting standards, safety, security, and other regulatory requirements.

NuPhotonics retains the right to change these resources without notice. All rights are reserved for NuPhotonics. NuPhotonics grants you permission to use the information in these resources to design with NuPhotonics devices. Reproduction and display of these resources is prohibited. No Third-party licenses are offered. You will fully indemnify NuPhotonics against any claims, damages, costs, losses, and liabilities that arise from you using these resources.

NuPhotonics does not accept and objects to any terms you have proposed.

For terms and conditions for all NuPhotonics products please refer to [www.nuphotonics.com](http://www.nuphotonics.com) Legal section.

Definitions: Product State

Alpha Build: Devices in Alpha build are in internal engineering build and testing stages. Major changes may happen for production build.

Beta Build: Devices in Beta build are for external customer and engineering sample testing stages. Minor changes may happen for production build.

Production Build: Customer ready devices. Small appearance changes may occur between devices.

Obsolete: Currently not supported.